



# XESR-03HS-EDDN

Project \_\_\_\_\_

Item \_\_\_\_\_

Quantity \_\_\_\_\_

Date \_\_\_\_\_

**Model**  
SPEED.Pro™

**Energy efficiency 15.9 kWh/day - 0 kg CO<sub>2</sub>/day\***

\*More details on the last page.

Baking speed oven	Electric
3 trays 460x330	Drop down opening
	6" Touch control panel
Voltage:	380-415V 3N~ / 220-240V 3~ / 220-240V 1N~



## Description

SPEED.Pro™ is the world's first and only speed baking oven: a convection oven and a speed baking oven in a single piece of equipment. Thanks to the large baking chamber of the SPEED.Pro™, you can use the Bake mode to bake up to 3 460 x 330 trays of bakery or pastry products, even frozen ones, obtaining perfectly uniform results. The Speed mode allows you to cook and regenerate food, in single or multiple portions, in record time thanks to the combination of controlled hot air flows, microwave technology and the special Speed.Plate baking tray that transmits heat by contact, perfectly toasting all bread-based products.

## Standard cooking features

### Manual cooking

- **Temperature:** 30 °C – 260 °C
- Up to 9 cooking steps
- 24 quick programs (12 Speed and 12 Bake)

### Programs

- 384 Bake programs
- 384 Speed programs
- **CHEFUNOX:** choose something to cook from the library and the oven will automatically set all the parameters (Bake)
- **SPEEDUNOX:** choose something to cook from the library and the oven will automatically set all the parameters (Speed)

### App and web services

- **Data Driven Cooking app & webapp:** check and monitor in real-time the operating conditions of your ovens, create and share new recipes. Artificial intelligence transforms consumption data into useful information and allows you to increase daily profits
- **Top Training app:** download the Unox Top.Training app and learn step by step all the secrets of your new oven's control panel

## Advanced and automatic cooking features

### Unox Intelligent Performance

- **ADAPTIVE.Cooking™:** automatically regulates the cooking parameters to ensure repeatable results
- **SMART.Preheating:** automatically sets the preheating temperature and duration
- **AUTO.Soft:** manages the heat rise to make it more delicate

### Unox Intensive Cooking

- **SPEED.Plus:** generates microwaves and distributes them evenly throughout the baking chamber
- **DRY.Plus:** rapidly extracts humidity from the cooking chamber
- **AIR.Plus:** multiple fans with reverse gear and 2 speed settings

### Key features

- High-resistance AISI 304 stainless steel cooking chamber
- Baking chamber with integrated tray supports
- Visual display of the baking status by means of multicoloured LEDs
- Crumb collection system integrated in the filter under the door
- Proximity door contact switch
- Integrated Wi-Fi
- **Wi-Fi / USB data:** download/upload HACCP data
- **Wi-Fi / USB data:** download/upload programs



# XESR-03HS-EDDN

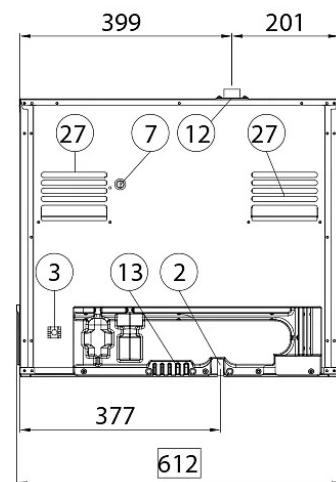
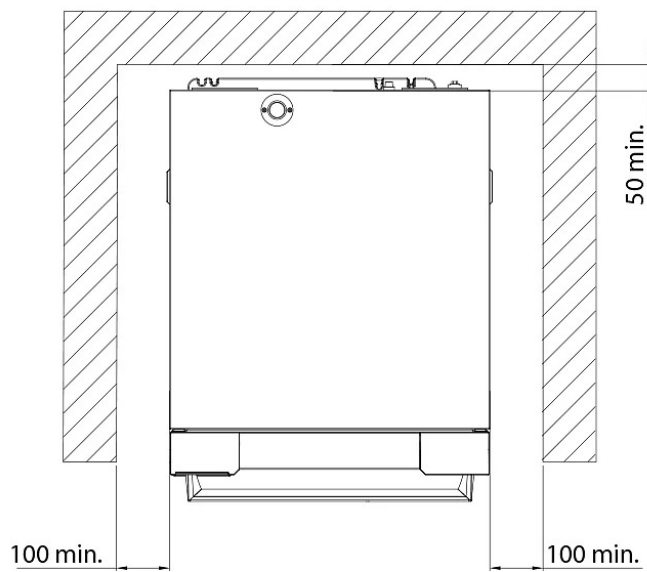
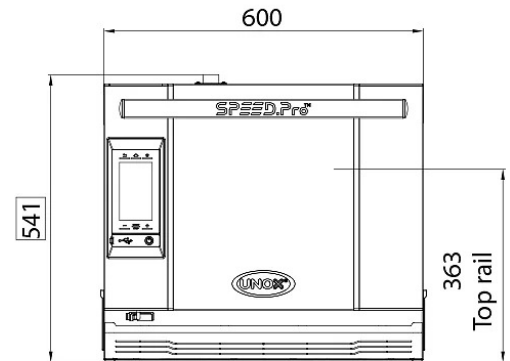
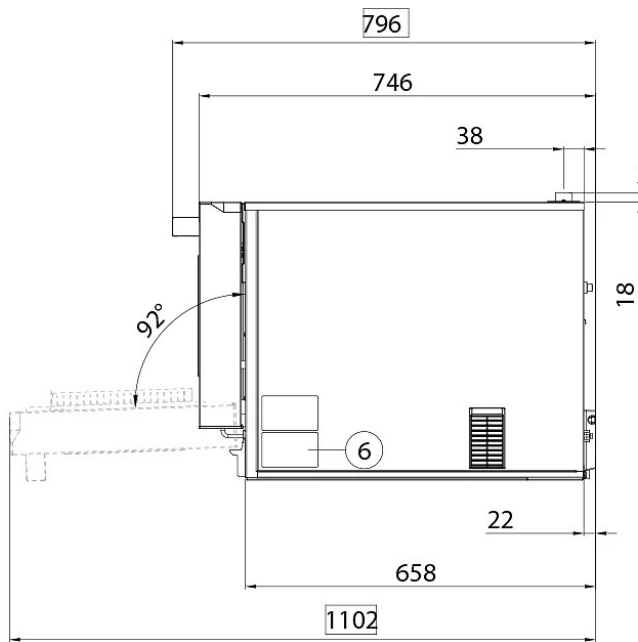

## Dimensions and weight

Width	600 mm
Depth	797 mm
Height	541 mm
Net weight	89 kg
Tray pitch	75 mm

## Connection positions

2	Terminal board power supply
3	Unipotential terminal
6	Technical data plate
7	Safety thermostat
12	Hot fumes exhaust chimney
13	Accessories connection

27	Cooling air outlet
----	--------------------



# XESR-03HS-EDDN

Power supply  
Water connection  
Installation requirements  
Accessories

## Electrical power supply

### STANDARD

Voltage	380-415V V
Phase	~3PH+N+PE
Frequency	50 Hz
Total power	6.6 kW
Max Amp draw	13 A
Required breaker size	16 A
Power cable requirements*	5G x 2,5 mm <sup>2</sup>
Plug	NOT INCLUDED

### OPTION A

Voltage	220-240V V
Phase	~3PH+PE
Frequency	50 Hz
Total power	6.6 kW
Max Amp draw	17.5 A
Required breaker size	16 A
Power cable requirements*	4G x 2,5 mm <sup>2</sup>
Plug	NOT INCLUDED

### OPTION B

Voltage	220-240V V
Phase	~1PH+N+PE
Frequency	50 Hz
Total power	6.6 kW
Max Amp draw	28.5 A
Required breaker size	32 A
Power cable requirements*	3G x 4 mm <sup>2</sup>
Plug	NOT INCLUDED

\*Recommended size - observe local ordinance.

## Energy efficiency

### Consumption

### CO<sub>2</sub> emission

\*\*The estimate includes only direct emissions produced by the oven. Indirect emissions can be reduced to zero by choosing to purchase energy from renewable sources.

### Estimate based on daily use of the oven (300 days/year):

6 light loads of roast chickens (loaded at 20%), 1 full load of roast potatoes, 3 full loads cooking with steam 2 hours in an empty oven at 180 °C.

### Estimated assuming the following weekly washing programs (42 weeks/year):

1 long wash, 1 medium wash.

## Accessories

- **SPRAY&Rinse:** Practical spray detergent to manually clean all kinds of oven. It degreases and removes all kind of dirt
- **Baking Essentials:** special trays for BAKE mode
- **Speed Essentials:** special trays and spatulas for SPEED mode
- **Ethernet:** Connection board to keep the oven connected to Unox and DDC.App

## Installation requirements

Installations must comply with all local electrical systems, particularly as for minimum wire gauge required for field connection, hydraulic and ventilation supply. Exhaust and fume analysis must be performed in case of gas ovens.

Register to DDC Service to access data and product specifications.  
[www.ddc.unox.com](http://www.ddc.unox.com)